

APPROXIMATE WEIGHT IS: 742.69 lbs.

- SELF-DUMPING STEEL HOPPER W/ BUMPER RELEASE - MODEL: D-150-HD

*** ANY ADDITIONS, DELETIONS, OR OMISSIONS MUST BE CORRECTED ON THIS DRAWING AS THIS DRAWING WILL BE CONSIDERED ALL INCLUSIVE ***
 ALL GRAPHICS PROVIDED ARE FOR REFERENCE ONLY. IF CERTAIN DIMENSIONS ARE CRITICAL PLEASE VERIFY THOSE DIMENSIONS WITH YOUR SALESPERSON

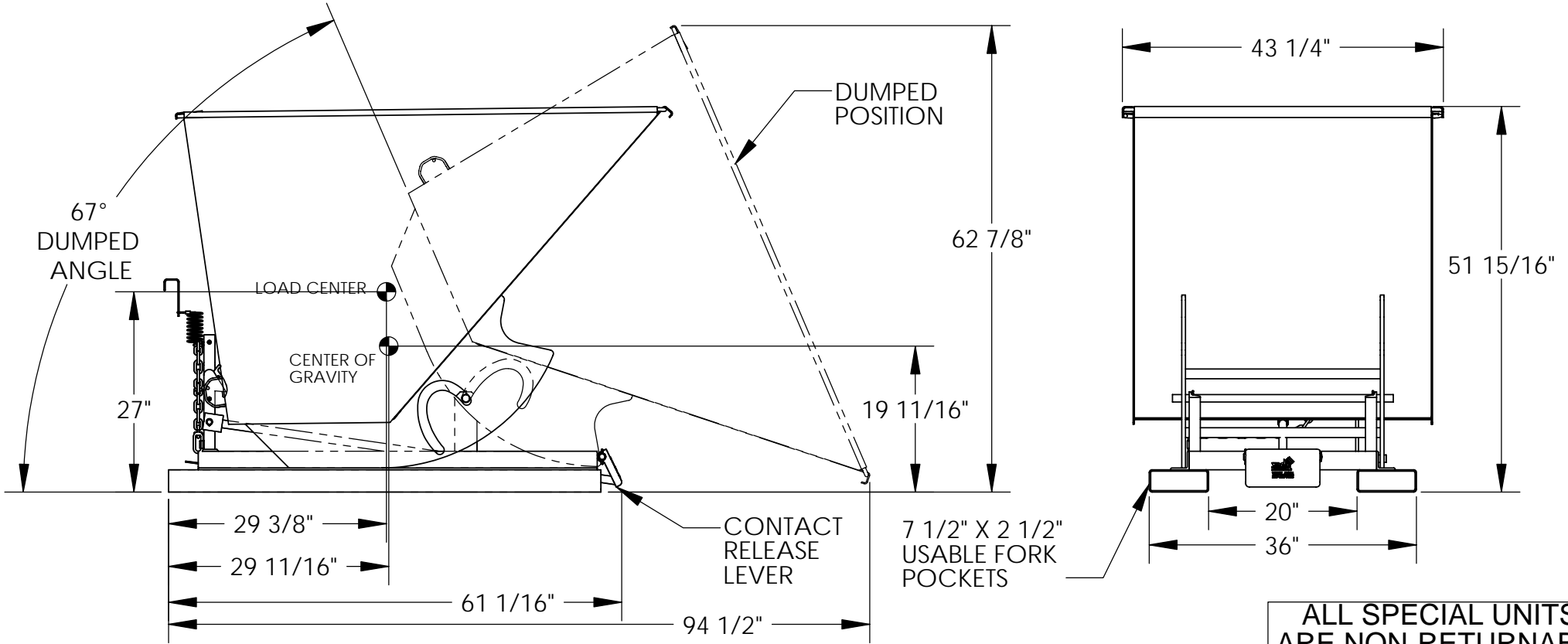

ALL SPECIAL UNITS ARE NON-RETURNABLE

STANDARD FEATURES

- VOLUME: 1 1/2 CU. YDS.
- CAPACITY: 6,000 LBS.
- OVERALL WIDTH: 43 1/4"
- OVERALL LENGTH: 94 1/2"
- OVERALL HEIGHT: 51 15/16"
- RELEASE CABLE LENGTH: 48"
- USABLE WORK ENVELOPE:
62"H X 99 3/4"L X 43 1/2"W

*****WITH CASTER OPTION, THE MAXIMUM WEIGHT CAPACITY IS THE LOWEST WEIGHT CAPACITY OF EITHER THE HOPPER OR THE CASTERS*****

SPECIAL FEATURES

NONE

OPTIONS	
PLEASE CIRCLE ALL THAT APPLY	
H - LEKP	D - LEKP
D - PLG	LUG
6 X 2 CASTER KIT ADDS 7 3/4" TO HEIGHT	8 X 2 CASTER KIT ADDS 9 3/4" TO HEIGHT
PLASTIC LID	

APPROVAL	I, the undersigned, hereby approve this print. This includes my approval of design & dimensions	
	[] As drawn [] As marked	
	Signed: _____ Date: _____	
	LEAD TIME WILL START UPON RECEIPT OF SIGNED APPROVAL DRAWING	

DISTRIBUTOR'S NAME: VESTIL MANUFACTURING		P.O.# X
DRAWN BY: W. STALEY	DATE: 5/7/08	SCALE: 1:20
REFERENCE: X	QUOTE # X	SALES: X
		FILE NAME: 37-007-013