

# LOW PROFILE MACHINERY GUARD - LPRO-36-16-2

APPROX WEIGHT: 10.87 lbs.  
 DOES NOT INCLUDE WEIGHT OF POWER OR PACKAGING!!!

\*\*\* ANY ADDITIONS, DELETIONS, OR OMISSIONS MUST BE CORRECTED ON THIS DRAWING AS THIS DRAWING WILL BE CONSIDERED ALL INCLUSIVE \*\*\*

ALL GRAPHICS PROVIDED ARE FOR REFERENCE ONLY. IF CERTAIN DIMENSIONS ARE CRITICAL PLEASE VERIFY THOSE DIMENSIONS WITH YOUR SALESPERSON

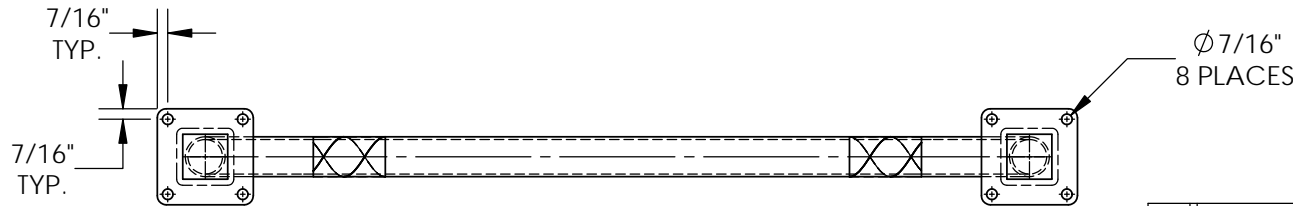
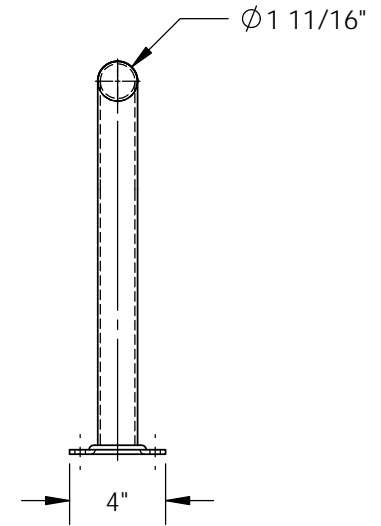
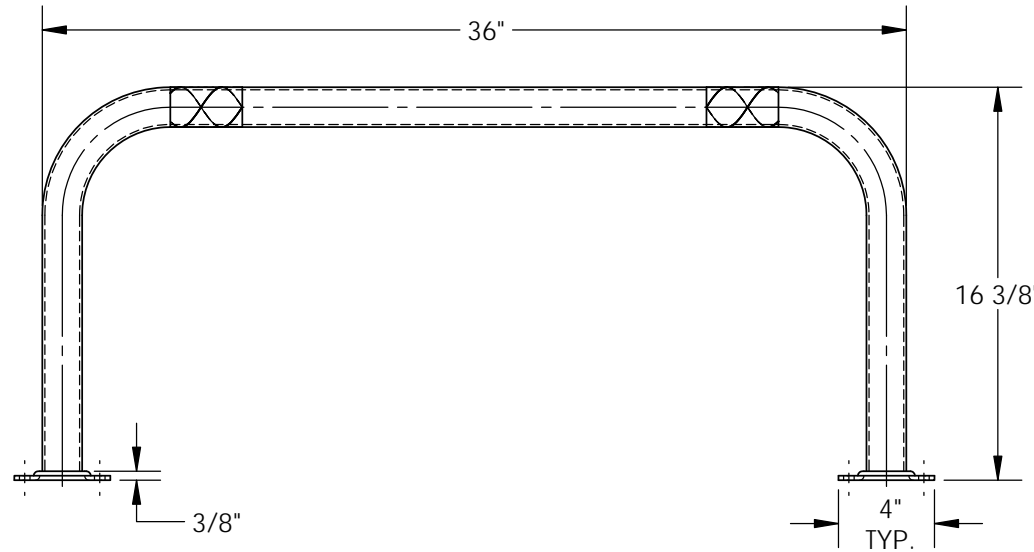

DIMENSION TOLERANCE  $\pm 1/4"$

## STANDARD FEATURES

- MODEL NUMBER IS LPRO-36-16-2
- MACHINE GUARD HEIGHT: 16 3/8"
- MACHINE GUARD LENGTH: 36"
- MACHINE GUARD DIAMETER:  $\text{Ø}1\ 11/16"$
- INCLUDES 2 MOUNTING BRACKETS
- YELLOW POWDERCOAT FINISH
- BLACK & YELLOW SAFETY TAPE
- ALL STEEL CONSTRUCTION (ASTM A-36 MIN.) WITH WELDING TO MEET AWS
- WARNING: CHECK APPLICABLE STATE AND LOCAL LAWS FOR YOUR AREA

## SPECIAL FEATURES

NONE

APPROVAL

I, THE UNDERSIGNED, AGREE THAT THE PRODUCT AS REPRESENTED SATISFIES DESIGN AND DIMENSION REQUIREMENTS. I ALSO ACKNOWLEDGE MY DUTY TO CONFIRM PRODUCT AND INSTALLATION COMPLIANCE WITH ALL APPLICABLE FEDERAL, STATE AND LOCAL REGULATIONS AND STANDARDS.  
**ALL SPECIAL UNITS ARE NON-RETURNABLE**  
 As drawn       As marked

Signed: \_\_\_\_\_ Date: \_\_\_\_\_

LEAD TIME WILL START UPON RECEIPT OF SIGNED APPROVAL DRAWING

DISTRIBUTOR'S NAME:		P.O.#
VESTIL MANUFACTURING		X
DRAWN BY: N. DEIBAN		DATE: 6/7/05
REFERENCE: X		SCALE: 1:8
QUOTED LEAD TIME: X	QUOTE # X	SALES: X
		FILE NAME: 23-007-129