

## STEEL STACKS

MODULAR • STACKABLE WELDED STEEL STORAGE RACKS • FLEXIBLE, LOW COST STORAGE SYSTEM FITS ANY SPACE

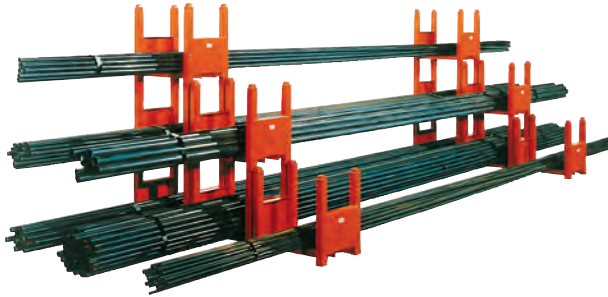

Steel Stacks are the answer to changing storage needs. Welded steel construction yet light weight—they can be easily shifted or changed as requirements change and stack safely up to four units high. Additions are inexpensive and easy to make—no tools required during initial set-up or moving. Steel Stacks are completely assembled and ready for instant use. Capacities up to 7500 lbs. total. Total stack capacity not to exceed capacity of one individual steel stack. Ideal for storing bar stock, pipe, tubing, molding, specialty lumber and parts. Used for storage of those small heavy items that do not store well on standard shelving. Low cost, maximum flexibility and minimum space requirements compare favorably to alternatives. Orange enamel finish.

### • ECONOMICAL SPACE-SAVING STORAGE

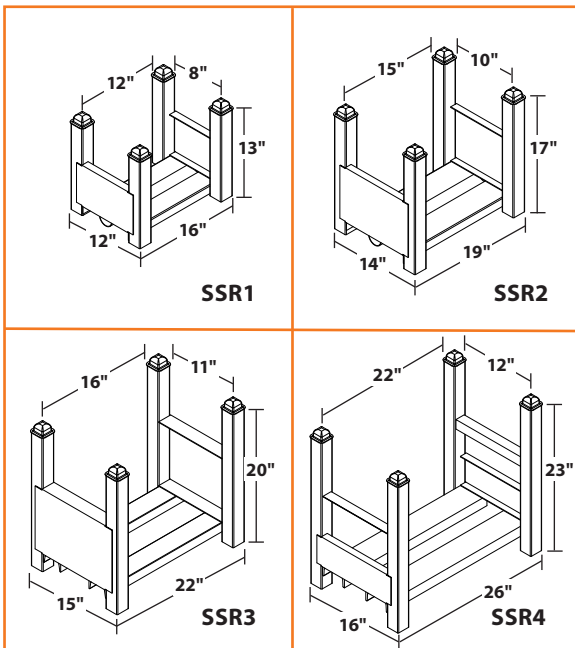

MODEL NO.*	NO. OF SECTIONS	LENGTH	WIDTH	HEIGHT	CAPACITY/SECTION	WEIGHT
SSR1	1	16"	12"	13"	2,500 lbs	19 lbs
SSR2		19"	14"	17"	3,750 lbs	28 lbs
SSR3		22"	15"	20"	5,600 lbs	47 lbs
SSR4		26"	16"	23"	7,500 lbs	56 lbs
SSM1-2	2	30"	12"	13"	2,500 lbs	41 lbs
SSM1-3	3	44"				58 lbs
SSM1-4	4	58"				73 lbs
SSM1-5	5	72"				88 lbs
SSM2-2	2	36"				14"
SSM2-3	3	53"	74 lbs			
SSM2-4	4	70"	85 lbs			
SSM2-5	5	87"	116 lbs			
SSM3-2	2	42"	15"	20"	5,600 lbs	
SSM3-3	3	62"				91 lbs
SSM3-4	4	82"				117 lbs
SSM3-5	5	102"				142 lbs
SSM4-2	2	50"				16"
SSM4-3	3	74"	130 lbs			
SSM4-4	4	98"	169 lbs			
SSM4-5	5	122"	207 lbs			

\* NOTE: THE FIRST NUMBER REFERS TO THE SIZE OF THE UNIT (SEE ILLUSTRATIONS AT LEFT). THE SECOND NUMBER REFERS TO THE NUMBER OF SECTIONS.

### How to select Steel Stacks:

1. Consider length, weight and rigidity of material to be stored.
2. Determine modular capacity from tables.
3. Determine length of material to be stored and select number of units required from illustration at right.
4. Determine quantity and dimensions of units required and order by model number from the above table.
5. Contact **MECO OMAHA** for special requirements.

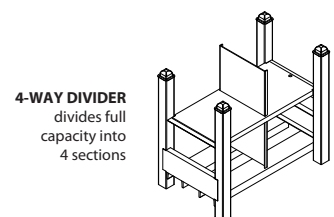
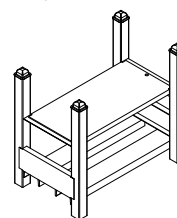
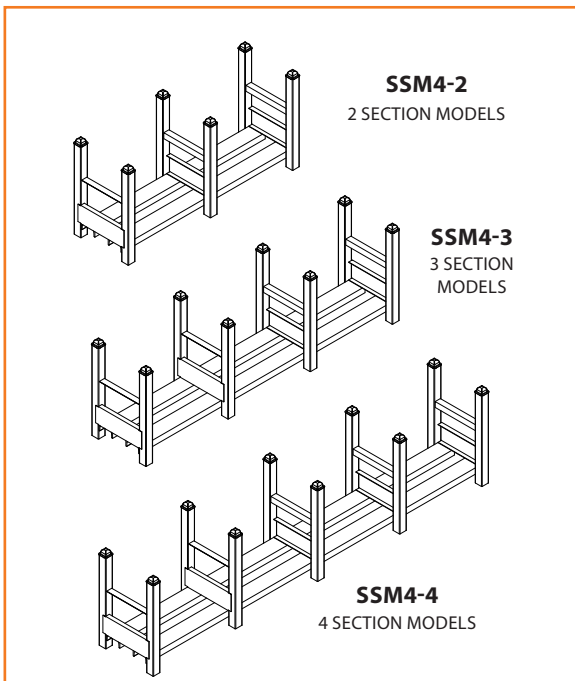
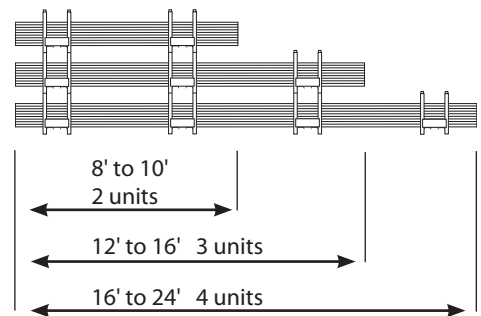

### • 2-WAY SHELVES AND 4-WAY DIVIDERS FOR STEEL STACKS

FOR USE WITH MODEL NUMBERS	2-WAY SHELF		4-WAY DIVIDER	
	MODEL NO.	WEIGHT	MODEL NO.	WEIGHT
SSR1 and SSM1	SSR1D	7 lbs	SSR1X	11 lbs
SSR2 and SSM2	SSR2D	8 lbs	SSR2X	17 lbs
SSR3 and SSM3	SSR3D	10 lbs	SSR3X	20 lbs
SSR4 and SSM4	SSR4D	14 lbs	SSR4X	26 lbs