

# ALUMINUM PALLET - AP-ST-4024

APPROX WEIGHT: 33.39 lbs.  
 DOES NOT INCLUDE WEIGHT OF POWER OR PACKAGING!!!

\*\*\* ANY ADDITIONS, DELETIONS, OR OMISSIONS MUST BE CORRECTED ON THIS DRAWING AS THIS DRAWING WILL BE CONSIDERED ALL INCLUSIVE \*\*\*

ALL GRAPHICS PROVIDED ARE FOR REFERENCE ONLY. IF CERTAIN DIMENSIONS ARE CRITICAL PLEASE VERIFY THOSE DIMENSIONS WITH YOUR SALESPERSON

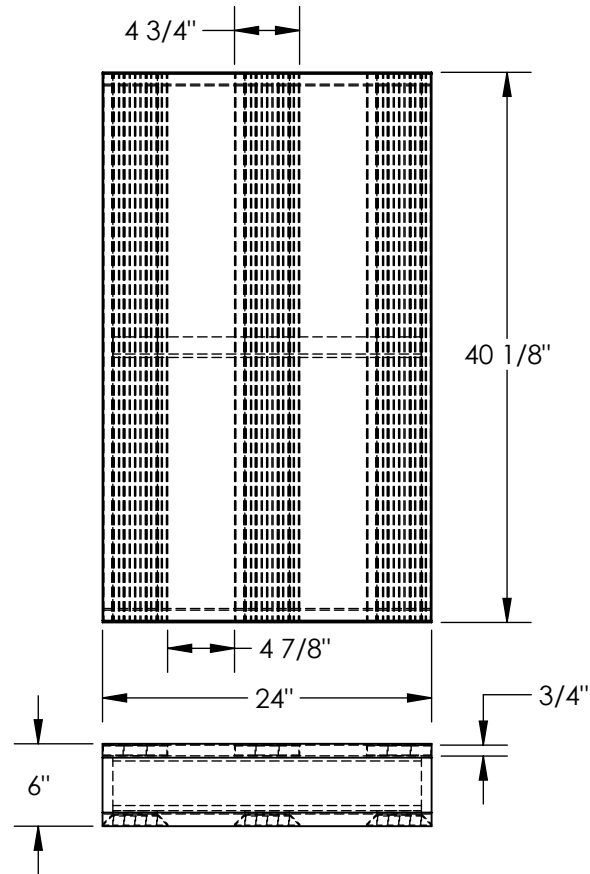

ALUMINUM SHEET WELDED TO UPPER EXTRUSIONS PROVIDES SOLID TOP

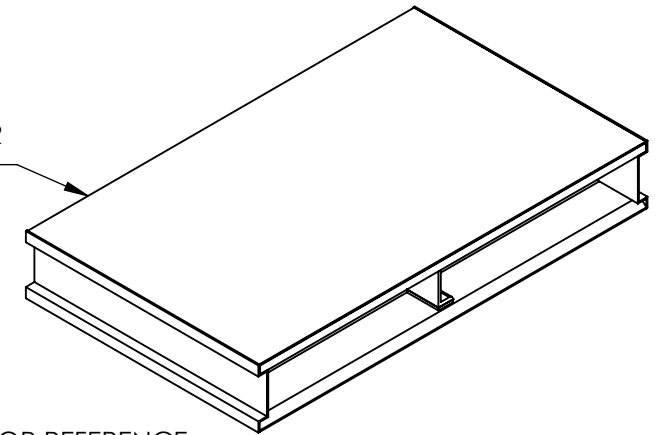

3D VIEW FOR REFERENCE

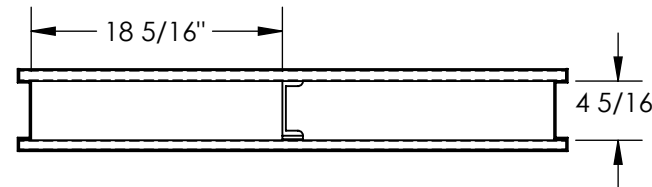

DIMENSION TOLERANCE ± 1/4"

## STANDARD FEATURES

- MODEL NUMBER IS AP-ST-4024
- ALL WELDED ALUMINUM CONSTRUCTION
- OVERALL WIDTH IS 40 1/8"
- OVERALL DEPTH IS 24"
- OVERALL HEIGHT IS 6"
- THICKNESS OF EXTRUSIONS IS 3/4"
- MAX. CAPACITY IS 4,000 LBS
- EVENLY DISTRIBUTED
- FORK OPENINGS ARE 18 5/16"W x 4 5/16"H

## SPECIAL FEATURES

NONE

<b>APPROVAL</b>	I, THE UNDERSIGNED, AGREE THAT THE PRODUCT AS REPRESENTED SATISFIES DESIGN AND DIMENSION REQUIREMENTS. I ALSO ACKNOWLEDGE MY DUTY TO CONFIRM PRODUCT AND INSTALLATION COMPLIANCE WITH ALL APPLICABLE FEDERAL, STATE AND LOCAL REGULATIONS AND STANDARDS.	
	<b>UNITS REQUIRING APPROVAL DRAWINGS OR MODIFIED ARE NON-RETURNABLE</b>	
	[ ] As drawn [ ] As marked	
	Signed: _____	Date: _____
	Printed Name: _____	
<i>LEAD TIME WILL START UPON RECEIPT OF SIGNED APPROVAL DRAWING</i>		

FOR INTERNAL USE ONLY PROJECT SIGN OFF		DISTRIBUTOR'S NAME:		P.O.#			
		<b>VESTIL MANUFACTURING</b>		X			
SALES		DRAWN BY:	MTS	DATE:	10/14/20	W.O.#	X
ENG.		REFERENCE:	X	SCALE:	1:14	SALES:	X
FAB.		QUOTED LEAD TIME:	X	QUOTE #	X	FILE NAME:	31-007-340
POWER							